

## TA-SF11R transcription tonearm

### Owner's manual

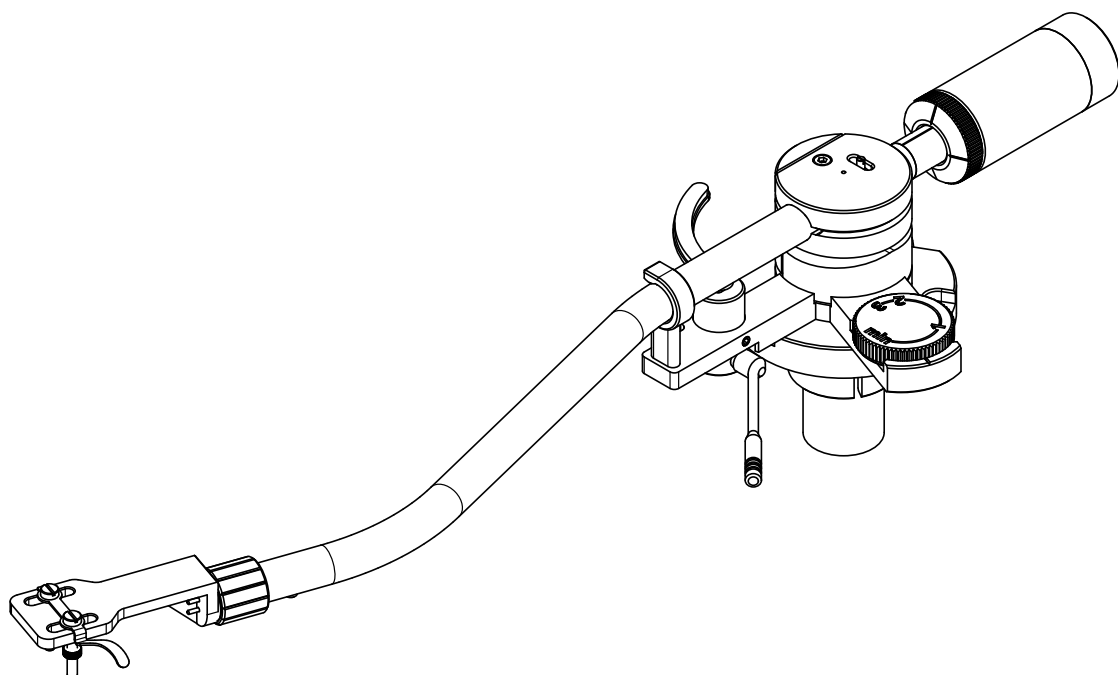

## **Welcome**

Thank you for choosing Korf Audio. Your new advanced precision tonearm incorporates many innovations for accurate distortion-free tracking of any record.

For example, a horizontal flexure pivot. Completely frictionless, yet locating the tonearm with perfect precision, without slack or any other extraneous movement. Greater rigidity, which is the single best prediction of outstanding audio performance in tonearms. Low resonances, achieved without elastic damping. The Korf tonearm is maintenance free, and very easy to use. It works optimally with virtually any cartridge, light or heavy, high compliance or low.

Your Korf tonearm is hand built in Austria. It should provide you with many years of superlative sound reproduction. To get the most out of your new tonearm and avoid disappointment, please read the entire manual and follow its recommendations.

This manual is written with an experienced analogue audio enthusiast in mind. If this is your first tonearm installation, kindly ask someone versed in installing and adjusting tonearms for help. Please understand that Korf Audio cannot be held liable for damage to the tonearm and your equipment that resulted from mishandling.

Enjoy your Korf tonearm, and thank you once again from everyone at Korf Audio.

A handwritten signature in black ink, appearing to read 'Alex Korf', written in a cursive style.

Alex Korf

## What's in the box?

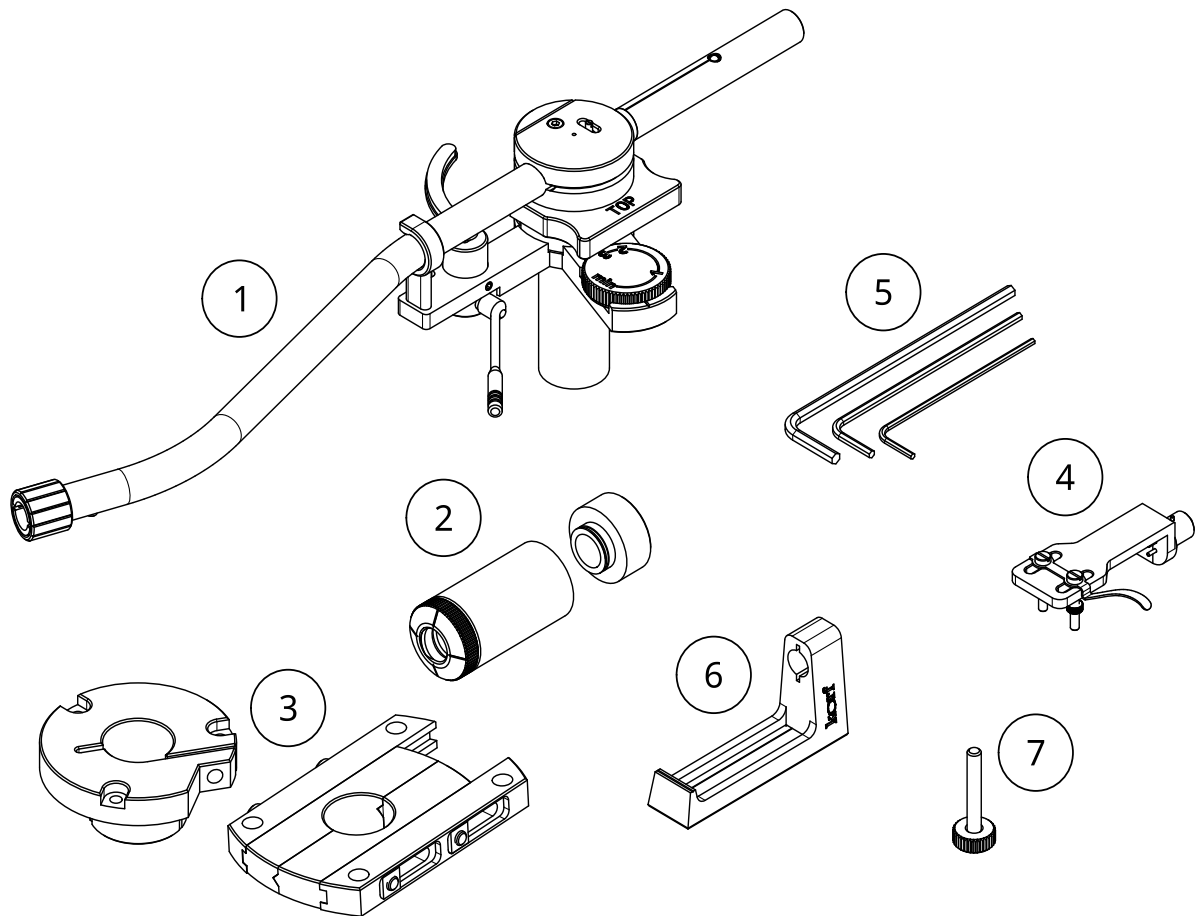

### The tonearm box contains

1. The tonearm itself, with the red transport spacer fixing its upper part in place
2. Two counterweights: the large main one and the small additional one
3. One or more arm bases as ordered
4. If ordered: headshell and mounting screws
5. Hex keys: 3, 2, 1.5 mm (may look different to illustration)
6. Stylus Gauge
7. VTA Thumbwheel

Inspect the box for signs of damage which might have occurred during transit. If heavily damaged, do not accept! If you have mistakenly accepted a damaged shipment, please notify us at [info@korfaudio.com](mailto:info@korfaudio.com). We will explain the necessary steps of returning the damaged box.



Save the packaging! You'll need it if you would want to return the Korf tonearm, sell it, store it or move it.



## Getting to know your Korf tonearm

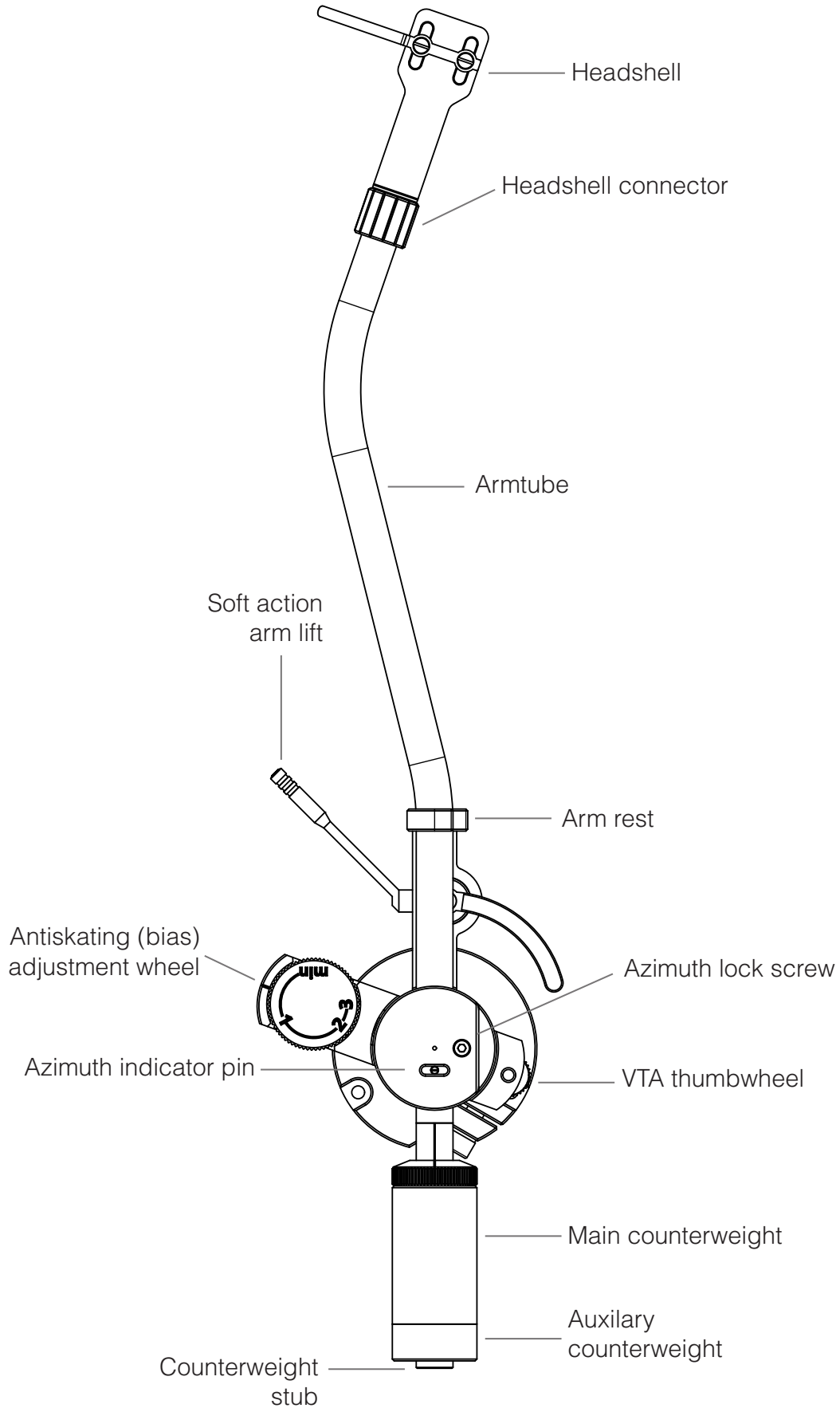

---

## Handling and Storage

Any quality tonearm is a delicate piece of equipment. Korf tonearms are not an exception. Mishandling the tonearm ruins its precision bearings. A conventional tonearm with broken bearings will still work after a fashion. The Korf tonearm with a broken flexure bearing instantly becomes unusable.

To prevent damage to the fragile horizontal flexure bearing:

- ! Remove and handle the tonearm by its lower part
- ! Never push on the tonearm from the top
- ! Never pull the tonearm by its top part, its arm tube or the counterweight stub.

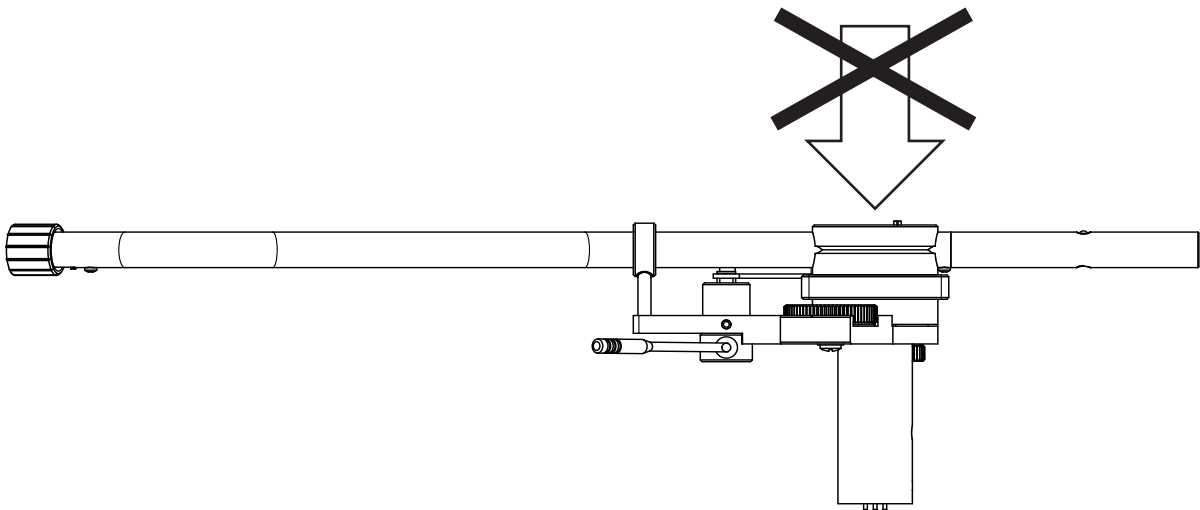

The plastic transport spacer protects the flexure bearing. Remove it once the tonearm is mounted on the turntable. There is no need to use the spacer in day to day operation of the tonearm. Please understand that the spacer cannot completely prevent damage from mishandling.

Avoid exposing the tonearm to

- ◇ Dust
- ◇ Particles (shavings, chips etc), especially magnetic
- ◇ Humidity

Do not disassemble. There are no user adjustable parts inside. In normal operation, the tonearm does not need servicing through its entire life.

## Mounting

The center of the arm base can be positioned anywhere on the 265 mm arc centered on the turntable spindle. Please mind the freedom of counterweight movement at all playing angles. Within these constraints, select any easy to reach position that is visually appealing to you. The next page has the cutout drawings for the two bases that can be supplied with the Korf tonearm. Make a 1:1 copy of it to have a cutout and holes template.

The tonearm has a dimple on top that marks its vertical pivot axis when the armtube is locked in the arm rest.



Make sure your turntable is exactly horizontal. Otherwise the Korf tonearm may operate incorrectly.

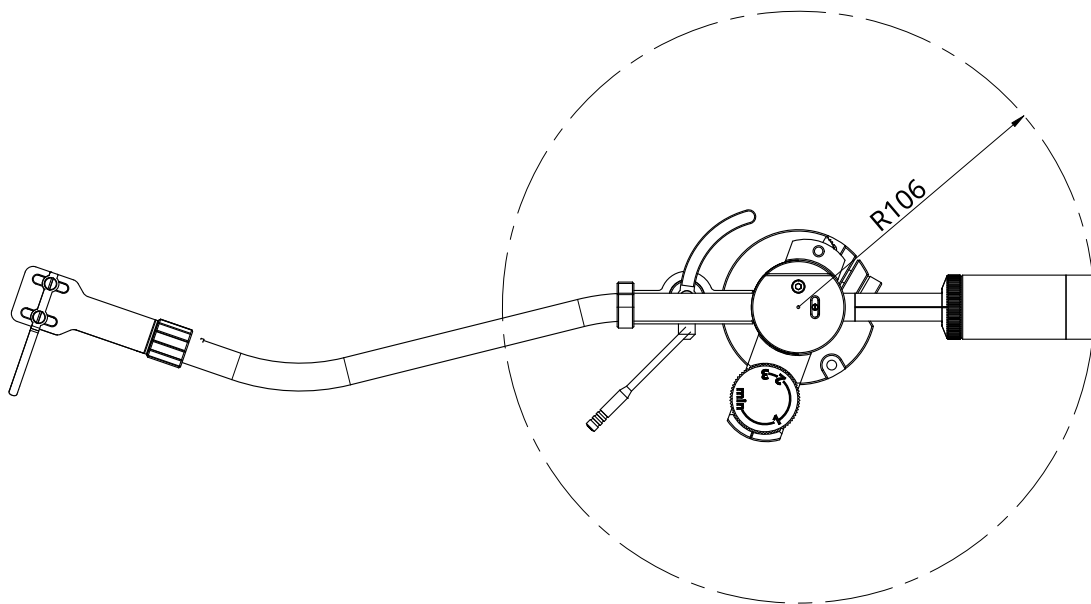
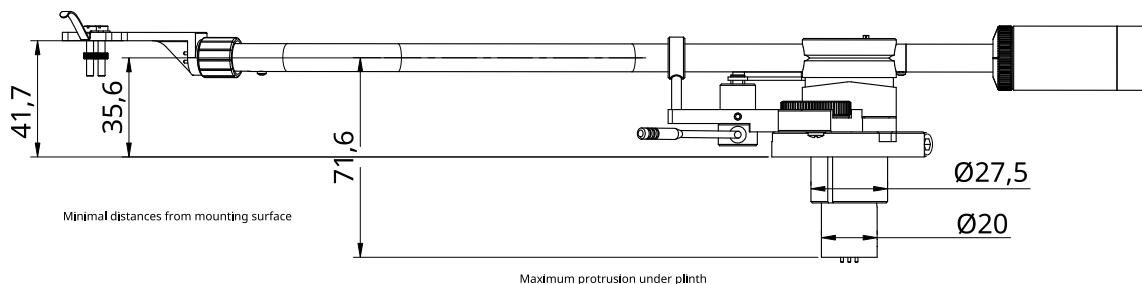

# Mounting Templates

JIS/Jelco/Linn mount

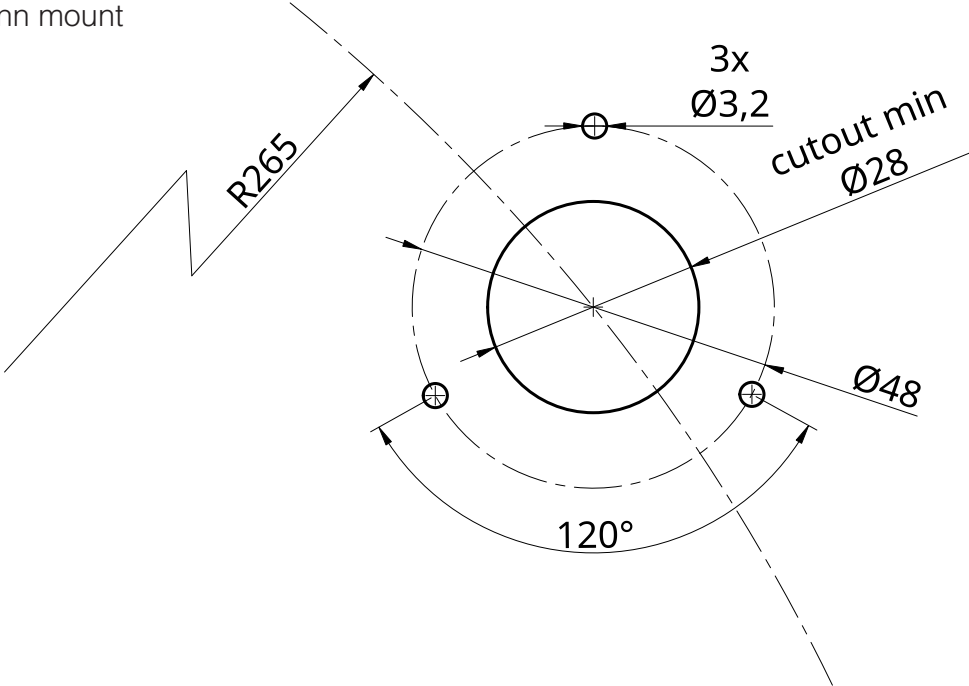

SME compatible mount

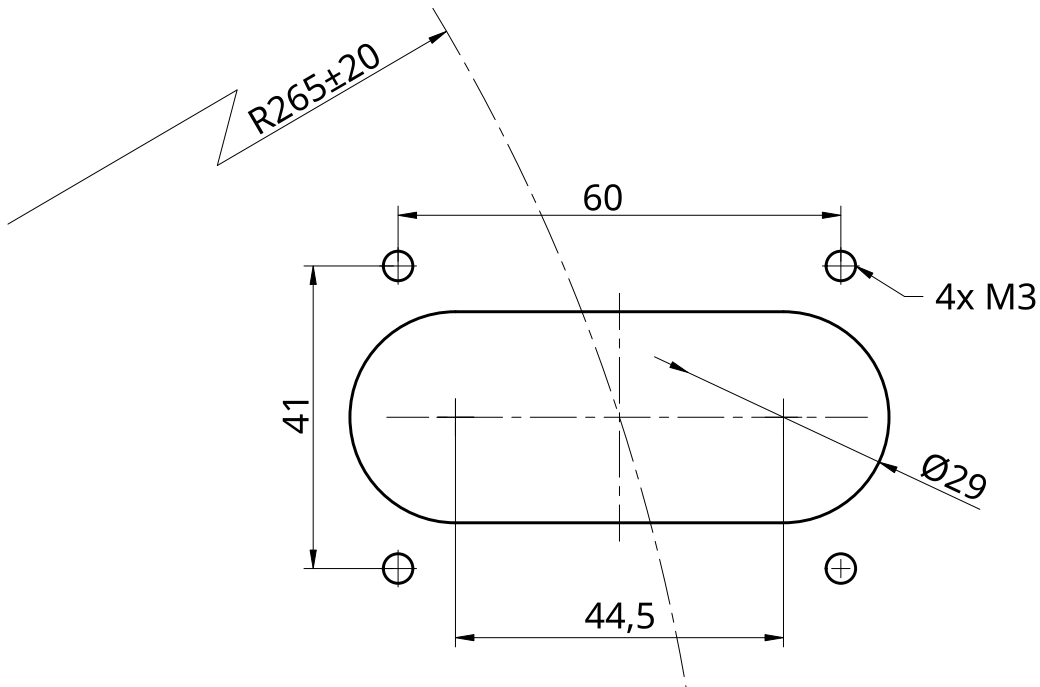

## Setting up your Korf tonearm

### Cartridge Alignment

Please use the included clip-on gauge to set the cartridge position in the headshell. Insert the headshell all the way into the protractor. Match the position of the stylus with the groove in the gauge.

Third party protractors may give an incorrect alignment; when in doubt please refer to the gauge.

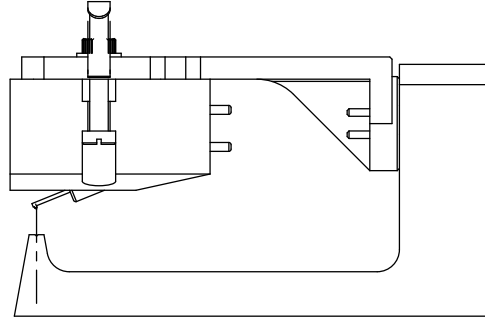

### Downforce

The vertical tracking force (downforce) is adjusted by rotating the counterweight.  $\frac{1}{4}$  of a turn corresponds to 0.5 gram change in downforce (when the additional counterweight is not installed). If your cartridge weighs more than 15 grams, please use an optional additional counterweight.

Unlike conventional tonearms, the Korf tonearm can not be balanced in the “zero downforce” position. This is by design. The zero friction horizontal bearing is disturbed by even the slightest movement of the air. Thus, the vertical tracking force must be set with a quality specialized downforce scale (not included with the tonearm).

### Antiskating

To set antiskating (bias), start with rotating the antiskating wheel to show approximately the same number as the set downforce. “Min” on the wheel stands for “minimum” and marks a zero position.

Refer to our website for more in-depth instructions.

### Tonearm Height

Use the included 3 mm hex key to adjust tonearm height. Loosen the clamp bolt(s) on the mounting base and then rotate the VTA thumbwheel to raise or lower the tonearm. Then tighten the clamp bolt(s) back.



---

## Azimuth

The Korf tonearm has a limited possibility to adjust the cartridge's azimuth. To adjust the azimuth:

- ◇ Place the transport spacer back into the tonearm, fixing the arm's upper part in place
- ◇ Undo the azimuth lock screw using the included 2 mm hex key, taking care not to press on the upper part of the tonearm
- ◇ Gently rotate the armtube, using the pin for visual reference
- ◇ When rotating the armtube, grip the upper part of the tonearm tightly and work against it. Do not apply any force to the flexure bearing
- ◇ Once the desired setting is achieved, tighten the azimuth lock screw.



We strongly suggest not changing the factory set azimuth. Only use this setting as a last resort to correct gross cartridge assembly errors. Flexure bearing damage from attempted azimuth adjustment is not covered by warranty.

## Specifications

### **11" transcription pivoting gimbal tonearm with removeable headshell**

Effective length	278 mm
Pivot to spindle distance	265 mm
Offset angle	19°
Effective mass without headshell	19 g
Effective mass with HS-A02 headshell	28 g
Horizontal axis bearing	Flexure pivot
Vertical axis bearings	Ceramic hybrid rolling bearings
Armtube material	Stainless steel
Headshell connector	Ortofon/SME/JIS type
Balance type	Static
Minimum mass of headshell and cartridge combination	10 g
Maximum mass of headshell and cartridge combination	35 g
Cable connector	5 pin MDIN, male
Internal wiring	OFC Litz
Available tonearm mounting bases	JIS/Jelco/Linn SME compatible
Mass without headshell and mount, max	360 g

## Limited Warranty

We promise to replace or repair your Korf tonearm free of charge if it fails due to manufacturing defects within 1 year from the date of delivery. If you are within the EU, we will pay to have it shipped to us and then back to you.

If you do not reside in the EU, you will need to cover the shipping costs. We will ship the repaired or replaced unit for free. You are responsible for customs fees or any taxes levied in your country on the repaired/replacement unit.

This warranty does not affect any rights that you might have as a consumer in your country.

For warranty repairs please write to [info@korfaudio.com](mailto:info@korfaudio.com), describing the nature of the problem. Please mention the country you are in in your email.

The warranty does not cover:

- ◇ Mechanical damage resulting from mistreatment
- ◇ Water and moisture damage
- ◇ Damage that resulted from attempted disassembly of the tonearm, or from any modifications to the tonearm
- ◇ Any consequential damage resulting from the use or misuse of the Korf tonearm

**Korf Audio GmbH**

Urberweg 34  
3400 Klosterneuburg Austria

For support, returns, warranty and general information  
please write to:

*info@korfaudio.com*

Device serial number

